



INSTRUCTION MANUAL

175 c.c. Bantam Supreme. Model D14/4

175 c.c. Bantam Sports. Model D14/4S

175 c.c. Bushman. Model D14/4B



INSTRUCTION MANUAL

175 c.c. BANTAM Supreme. Model D14/4

175 c.c. BANTAM Sports. Model D14/4S

175 c.c. BUSHMAN. Model D14/4B

**B.S.A. MOTOR CYCLES LTD., ARMOURY ROAD,
BIRMINGHAM, 11 ENGLAND**

*Telephone: Birmingham, VICToria 2381
Telegrams and Cables: "SELMOTO," Birmingham.*

*B.S.A. Motor Cycles Ltd. Reserve the right to alter the designs or any
constructional details of their manufacture at any time without giving notice.*

Printed in England

Reproduced August 2003 by Tom Seale
Copyright B.S.A. Co. Ltd. July, 1967

This Instruction manual is intended to acquaint the B.S.A. owner with details of the controls, general maintenance and technical data which may be required for normal operation of the machine.

It does not contain the information necessary to carry out complete stripping for major overhauls, but if any owner feels competent to carry out this type of work, a service manual and an illustrated spares catalogue for this machine can be obtained from his B.S.A. spares stockist or local dealer.

Owners in the British Isles can obtain these publications direct from B.S.A. Motor Cycles Ltd., Service Department, Armoury Road, Birmingham 11. Always quote full engine and frame numbers when ordering these publications.

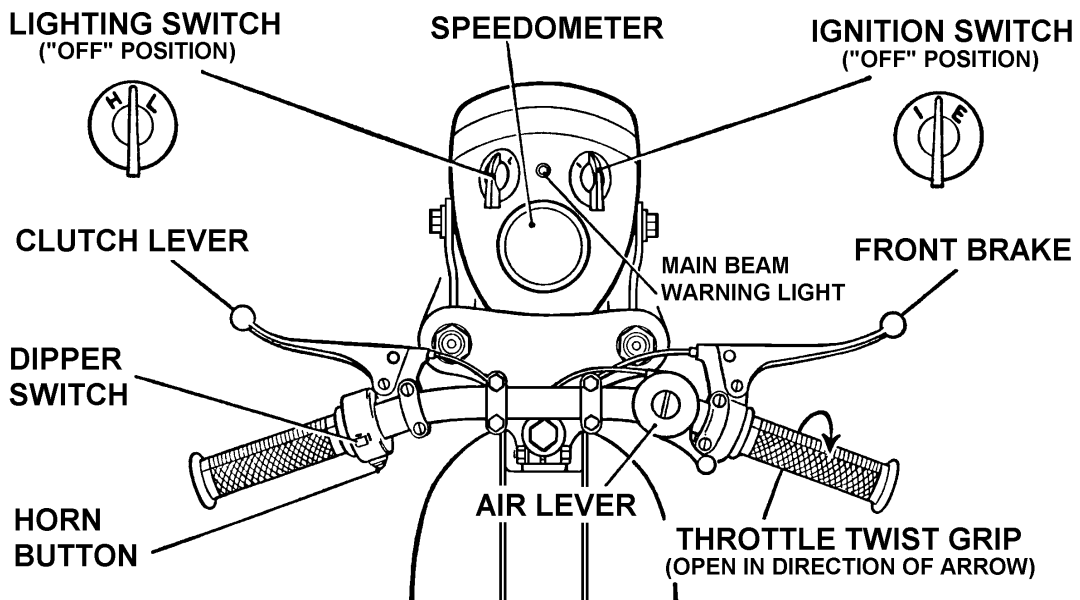

The controls of the Bantam Sports. Note: Bushman models are not fitted with an ignition switch, main beam warning light, or parking light, but are otherwise similar.

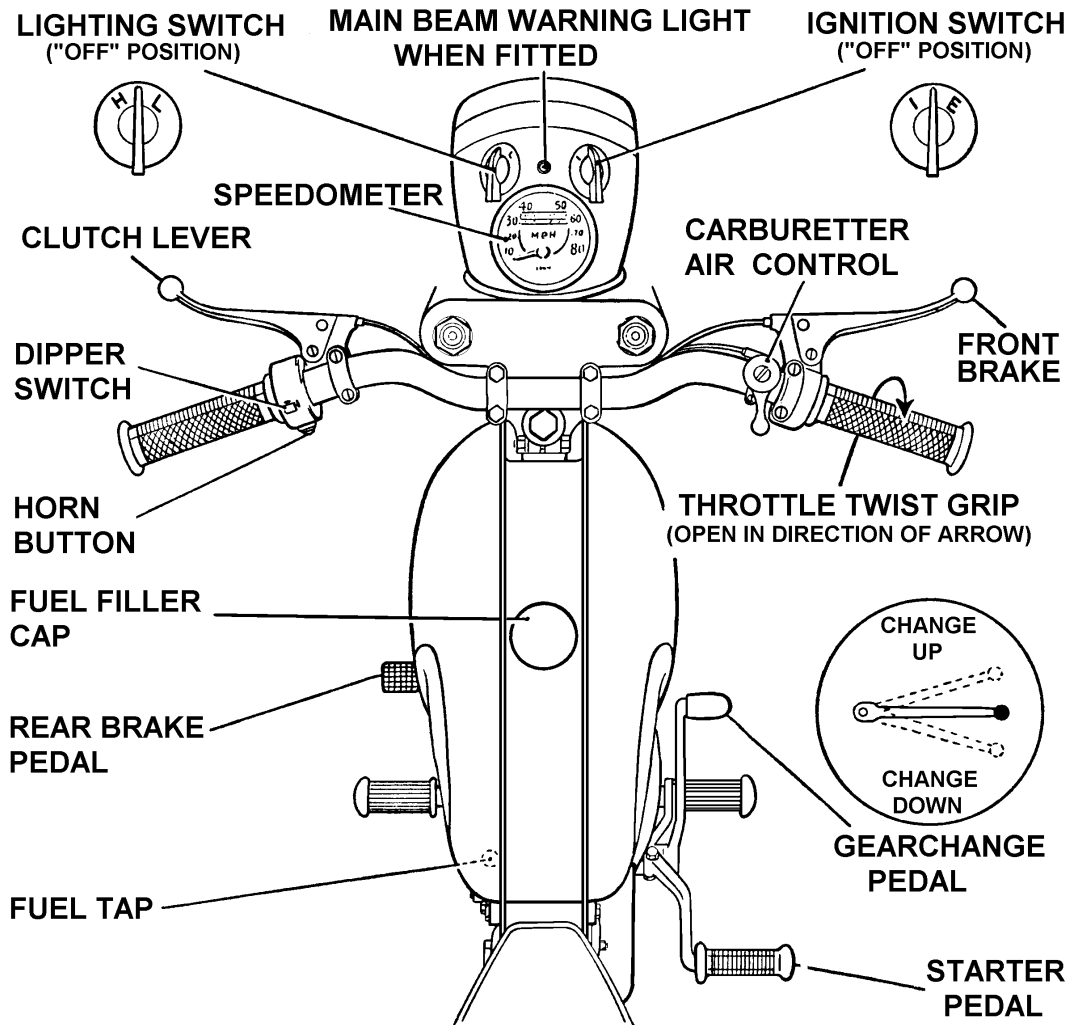

Fig. 1. The Controls

The lower illustration shows the controls for the Bantam Supreme.

CONTENTS

	pages
AIR CLEANER	20
BRAKES	28
CARBURETTER	18
FRONT CHAIN	24
REAR CHAIN	28
CLEANING	11
CLUTCH	25
CONTROLS	7
CYLINDER HEAD AND BARREL REMOVAL	15
DRIVING	8
DECARBONISING	15
ELECTRICAL EQUIPMENT	30 and 32
FORKS	28
GEARBOX	26
HUBS	26
IGNITION TIMING	13
LUBRICATION CHART	22, 23
LUBRICATION (ENGINE)	12 and 22
ROUTINE MAINTENANCE	11
REAR SUSPENSION	29
RUNNING-IN	10
SPARKING PLUG	17
STEERING HEAD	29
TECHNICAL DATA	5 and 6
TRANSMISSION	24
WHEEL REMOVAL (FRONT)	27
WHEEL REMOVAL (REAR)	27
WIRING DIAGRAM	34, 35

TECHNICAL DATA

Engine Number—on top of crankcase below cylinder.

Frame Number—at top of steering head tube.

Engine:

Capacity	173 c.c.
Cylinder bore	61·5 mm.
Stroke	58 mm.
Compression ratio	10/1
Piston ring gap	minimum	·009 in.
								maximum	·013 in.
Sparking plug	N4
Plug points gap	minimum	·020 in.
								maximum	·025 in.
Contact breaker points gap	·012 in.
Ignition timing (fixed)	18 degrees (before T.D.C.)

Transmission:

							Supreme, Sports	Bushman	
Gear ratios	top	6·58	8·1	
						third	8·55	10·5	
						second	12·04	14·8	
						first	18·68	23·0	
Clutch—friction plates	4	4		
Chain size and pitch	
									front $\frac{3}{8} \times \cdot 250$ in.
rear $\frac{1}{2} \times \cdot 335$ in. roller	120 pitches	128 pitches
Teeth on: engine sprocket	17	17
gearbox sprocket	16	16
clutch sprocket.	38	38
rear chainwheel	47	58

Capacities:

Fuel tank	1 $\frac{7}{8}$ gallons
Petrol mixture	See pages 12 and 22
Gearbox	1 pint
Front forks	$\frac{1}{8}$ pint
									(Supreme), $\frac{1}{6}$ pint (Sports and Bushman) each leg

TECHNICAL DATA

Wheels:

								Supreme, Sports	Bushman
Gear ratios	front	3·00—18	3·00—19
							rear	3·00—18	3·00—19
Tyre pressure	front	16 p.s.i.	16 p.s.i.
							rear	22 p.s.i.	22 p.s.i.
Brake size	dia.	5½ in.	5½ in.
							wide	1 in.	1 in.

Carburation: Amal

Bore	26 mm.
Main jet	150
Pilot jet	25
Throttle valve	3
Needle position	2
Needle jet	·105

General Details:

						Supreme	Sports	Bushman
Overall length	77½ in.	77½ in.	78 in.
Wheelbase	50 in.	50 in.	50 in.
Ground clearance (at crankcase)	6¾ in.	6¾ in.	10 in.
Seat height	31 in.	30¼ in.	30½ in.
Overall height	36½ in.	36½ in.	40½ in.
Handlebar width	27¾ in.	23 in.	27¾ in.

- ◆◆ The recommended tyre pressures are based on a rider's weight of 154 lbs. If the rider is heavier, increase the pressures as follows: —

Front tyre: Add one lb. Per sq. in. for every 28 lb. Increase above 154 lb.

Rear tyre: Add one lb. Per sq. in. for every 14 lb. Increase above 154 lb.

If additional load is carried in the form of a pillion passenger or luggage, the actual load bearing upon each tyre should be determined and the pressures increased in accordance with the Dunlop Load and Pressure Schedule

TAKING OVER THE MACHINE

Before running the machine make sure that the fuel tank contains the correct mixture of oil and petrol, that the gearbox is properly topped up with oil and that the battery is filled and charged. (See appropriate chapters for filling instructions). Normally these preparations will be carried out by the dealer who is selling the machine and the new owner has only to arrange the controls to his liking and the machine is ready for the road.

The Controls

The new rider should make sure that he is quite familiar with all the controls before attempting to ride the machine. Most of the controls are adjustable and should be positioned so that they can be reached without moving the hands from the grips or the feet from the footrests. Handlebars should be adjusted so that a comfortable and natural riding position is achieved. Make sure that the bolts retaining the handlebar clamps are tight after completing any adjustment. Badly positioned controls cause poor control of the machine and will bring discomfort on long journeys.

Handlebar Controls

Twist Grip.—Mounted on the right handlebar it controls the throttle opening and consequently the engine speed. To open the throttle (i.e. to increase the engine speed) turn the grip so that the top moves towards the rider. Excess slackness in the cable can be removed by means of an adjuster incorporated in the cable at the carburetter end.

The rotary stiffness of the twist grip can be varied by means of the adjuster screw and locknut. It is set for average requirements when leaving the factory, but can be readjusted to suit individual preference.

Front Brake.—Lever mounted on the right handlebar in front of the throttle control. Grip the lever gently to operate the brake.

Clutch.—The lever is mounted on the left handlebar. Grip the lever to free the clutch, i.e. to disengage the drive between the engine and the rear wheel.

Horn.—The horn button is mounted on the left handlebar and is incorporated in the headlight dipper switch.

Headlight Dipper Switch.—Controls the switching from main to dipped headlight beams and is mounted on the left handlebar.

Cut-out Button.—On Bushman models, an ignition cut-out is provided on the left handlebar and is mounted on the same body as the horn button and headlight dipper switch.

Headlight Warning Light.—On Supreme models for U.S.A. only, a red warning light on the headlight body indicates when the main beam is in use. On Sports models the warning light is a standard item.

Other Hand Controls

Carburetter Air Control.—Situated on the right handlebar, adjoining the front brake lever. When closed (moved away from the rider) a rich mixture is provided for starting purposes. For normal running, the lever should be turned clockwise as far as possible. Cable adjustment is at the carburetter.

Petrol Tap.—Under the rear end of the tank. To turn on the petrol, pull out the serrated button and lock in position by turning anti-clockwise. To turn off the petrol, reverse this procedure.

Headlight Switch.—This is operated by a switch on the headlamp, and has three positions—OFF, LOW (L), and HEAD (H) respectively. The low position is for use when the machine is stationary and applies only to Supreme and Sports.

Ignition Switch.—(Supreme and Sports models)—This is mounted on the top of the headlamp and has three positions. With the pointer straight ahead, the ignition is switched off, and the switch should always be retained in this position when the engine is stationary, otherwise after several hours (say, over-night) the battery may become discharged. For normal starting, rotate the switch until the position marked “I” is straight ahead. For emergency starting with a discharged battery, rotate the switch until position “E” is straight ahead. (Important—See Electrical Equipment).

Carburetter Tickler.—This is a small plunger above the float chamber. Pressing it down pushes down the float and frees the needle valve thus permitting the carburetter to receive excess petrol.

Steering Lock.—Provision is made for locking the steering. Turn the forks to the left, when the hole in a special frame lug will coincide with the corresponding hole in the bottom yoke lug. Locking the two lugs together by means of a padlock, prevents the machine from being driven or wheeled away.

Foot Controls

Rear Brake.—On the left-hand side of the machine controls the rear brake only.

Gear-change Pedal.—On the right-hand side of the engine there are two pedals one of which projects forward, this being the gearchange pedal. It affects the change from one gear to another. The lever is of the positive stop type and returns to the central position after each change. Upward movement of the lever selects the next higher gear, downward a lower gear. Neutral is between first and second gear.

Starter Pedal.—This is the other pedal on the right-hand side of the engine. Depression of the pedal rotates the engine.

Instruments

Speedometer.—This is mounted centrally in the headlight body and records speed and total mileage.

DRIVING

To Start the Engine

On Supreme and Sports models, first turn the ignition switch to the position marked “I” (see “Controls”). It will be impossible to start the engine until this has been done.

Stand astride the machine and make sure that the gears are in the neutral position, which lies between the first and second gears. If there is any doubt about this, depress the gearchange pedal fully two or three times to engage successively lower gears, at the same time easing the machine backwards and forwards to allow the gears to rotate a little and so facilitate gear engagement. When it is certain that first gear is obtained, raise the pedal by half its normal stroke, so selecting the neutral position. Should the machine be in gear it will move forward as the starter pedal is depressed.

If the engine is quite cold, depress the carburetter tickler momentarily. Note that it is neither necessary nor desirable to oscillate the tickler rapidly, as this may damage the float. Close the carburetter air control, thus giving a rich mixture for starting (see page 19).

Open the twist grip a small amount only, as excessive opening may prevent easy starting, and push the starter pedal down slowly until resistant is felt; then, without releasing the pressure on the pedal, give a firm downward swing which should set the engine in motion. If the engine fails to start at the first attempt, repeat this procedure, being careful to avoid rapid kicking at the pedal which will serve no purpose and may damage the operating mechanism.

Note that while it is necessary to use the carburetter air control when starting from cold, this may not be necessary when the engine is warm, and should certainly not be so if a re-start is made after a short wait only. During normal running the air control must always be kept fully open and it should be opened immediately the engine fires, or should the weather be cold, at the earliest possible moment.

Engaging First Gear

With the engine running slowly, disengage the clutch by gripping the left handlebar lever and after a brief interval press down the gearchange pedal as far as it will go, so selecting first gear. If the pedal will not move through its full travel, so that the gear does not engage, ease the machine backwards or forwards slightly, maintaining a light pressure on the pedal, until the gear is felt to engage.

Moving Off

Open the throttle slightly and gently release the clutch lever part way, until the clutch can be felt to take up the drive, and the machine tends to move forward. Open the throttle a little more to prevent the possibility of stalling the engine, and slowly release the clutch lever as the machine moves away. Until the lever is completely released the clutch is not fully engaged, so that the engine should not be speeded up excessively or the clutch remain partly engaged, for longer than is necessary to get the machine away in first gear.

Changing Gear (Up)

When the machine is moving steadily with the clutch fully engaged, the next operation is to engage second gear. Close the throttle, disengage the clutch, and raise the gearchange pedal as far as it will go, the three movements being performed simultaneously. Immediately the gear is felt to engage, re-open the throttle and re-engage the clutch. A similar procedure is necessary for each upward gearchange.

Changing Gear (Down)

Open the throttle slightly, disengage the clutch, and press the gear change pedal down as far as it will go. Re-engage the clutch as soon as the gear is felt to engage. Violent pressure on the gear lever is unnecessary, a steady movement of the pedal being most effective. All downward gearchanges should be made in a similar manner.

To Select Neutral

Neutral is situated between first and second gears. To select neutral from first gear, withdraw the clutch and lift the gearchange pedal gently until it is felt to click into the neutral position. If the lever is lifted up too far it will travel through to second gear.

To Stop the Engine

Select the neutral gear position and close the throttle so reducing the engine speed to “tick-over”. Turn the ignition switch to the “OFF” or central position, or, on Bushman models, depress the “cut-out” button to stop the engine.

Notes on Gear Changing

When changing gear, not only should a suitable road speed be selected at which to perform the operation, but the gear change should be timed in such a way that the relative speeds of the engine and gearbox coincide as closely as possible. For this reason, when changing up, the throttle is momentarily closed when disengaging the clutch, allowing the engine (and corresponding gearbox pinions) to slow down to the lower speed at which they will operate in the next higher gear.

When changing to a lower gear, the engine speed has to be increased relative to the road speed, and the throttle should not therefore be closed, but even opened slightly, while making the change. As soon as the clutch lever is gripped, the engine will automatically increase in speed, and the lower gear will engage quietly at the correct speed.

Changing gear therefore whilst appearing complicated is mainly concerned with the synchronisation of engine speed and road speed, by co-ordination of hand and foot operations. After a little practice, smooth and quiet gear changes will be possible at all items and eventually become a purely automatic action.

Using the Gearbox

Correct use of the gearbox must be made in order to obtain best results in all round performance, especially with regard to acceleration and hill climbing capabilities.

It is not always appreciated that the power developed by an I.C. engine depends upon the engine speed. Hence, on a machine travelling up hill the engine speed will fall as a result of the increased load, with a corresponding fall in power output. In order to maintain sufficient power, a lower gear must be selected in order to increase the engine speed and so obtain more power.

Similarly, for good acceleration from moderate speeds in top gear, more power is required and here again the solution is to change down to a lower gear. **It is better to allow the engine to “rev” in a lower gear than to labour in a higher one.**

Riding Hints

Use the throttle to control the speed of the machine, as gentle but definite braking is obtained by merely closing the throttle. On wet roads and particularly under icy conditions, the use of the engine as a brake is to be recommended. A change to lower gear increases the braking effect.

Try to anticipate the need to change gear or to brake, so that changes in speed are smoothly carried out. Always use both brakes together and apply them smoothly and progressively. Never accelerate or brake fiercely, especially on bends or wet roads. Both actions are signs of an inconsiderate driver and always remember, a good driver is the most unobtrusive.

RUNNING-IN

The rider who has just purchased a new machine will do well to remember that all the internal parts are just as new as the enamel and plating which can be seen, and they must be well “run-in” before the engine can be given really hard work.

The “running-in” process is the most important period in the life of the engine, and the handling it receives during the first 1,000 to 1,500 miles will determine the service which it will provide in return.

Running-in should commence at $\frac{1}{3}$ to $\frac{1}{2}$ throttle and the throttle opening should be progressively increased as the mileage builds up, until at the end of the running-in period full throttle can be employed.

If excessive speeds are used in the early stases, there is risk of seizure and other troubles and in any case until the machine has been properly run-in it cannot be expected to give its best performance.

Smooth throttle control and selection of the correct gear for the prevailing conditions will ease the work of the engine. In particular avoid violent acceleration, and do not allow the engine to labour on hills in high gear when a change to a lower gear would ease the load. This ensures that all parts of the machine are properly run-in and are quite free.

Carry out the periodical maintenance details described later with faithful regularity.

After the first 250 miles (400 km.), remove the smaller of the two screwed plugs from the bottom of the crankcase and drain out any oil which may have accumulated there. With the petroil lubrication system employed there is never a considerable quantity of liquid oil in the crankcase, but whatever oil there is should be drained away, and this is preferably done while the engine is warm immediately after a run, as the oil will flow more freely and carry with it any foreign matter which may have found its way into the crankcase during the running-in process.

Make certain on replacing the plug that it is made really tight in order to prevent loss of crankcase compression.

During the running-in period the gearbox should also be drained and flushed out and this is preferably done at the same time as the crankcase is drained. Information regarding the correct grades of oil is given in the table on page 22.

ROUTINE MAINTENANCE

To keep the machine in good condition and provide trouble-free running, maintenance must be regularly carried out. The following list of items requiring regular attention will serve as a guide to the periods between servicing and the method of carrying out the various adjustments will be found under the appropriate headings in the later chapters.

Obviously regular and thorough cleaning will keep the machine looking smart and will help to retain both its new appearance and value. But it helps also to lengthen its life and maintain efficiency if the cleaning process is carried out correctly.

Take special care to prevent dust and grit from working into such parts as hubs, carburetter, brakes and gearbox.

To rub dry and caked mud from the frame, tank and mudguards means that the enamel on these parts will be subjected to an abrasive action which will quickly destroy the polish. Soak the mud first, and then float it off with copious supplies of clean water supplied either with a hose or a sponge. If a hose is used, take care not to direct the stream of water directly on to the hub bearings, and carburetter.

When all dirt is removed, dry and polish. Autobrite is recommended for this purpose.

The engine and gearbox are best cleaned with a brush and paraffin, and then dried off with a clean rag.

Weekly	page
Check tyre pressures and remove any embedded stones or pieces of metal.	
Oil brake pedal pivot and all exposed joints and cables.	
Examine the battery and top up if necessary. More frequent examination is advisable in a hot climate	30
Check brake adjustment	28
Every 1,000 miles	
Check rear chain adjustment	28
Check oil level in gearbox and top up if necessary	26
Clean air filter	20
Grease swinging fork pivots (2)	29
Grease clutch control	25
Oil central stand pivots.	
Every 2,000 miles	
Check tightness of all nuts and bolts.	
Change oil in gearbox	26
Grease brake cams.	
Grease speedometer drive	26
Every 5,000 miles	
Check contact breaker adjustment and grease the felt pad	13
Every 10,000 miles	
Drain and re-fill front forks	28

ENGINE

Lubrication

Lubrication for the engine is provided by oil dissolved in the petrol to provide a mixture commonly called “petroil”. The filler cap on top of the petrol tank will be found to incorporate a tubular extension which projects into the tank. This serves as a measure for lubricating oil and is used for preparing the correct mixture of petrol and oil required. The correct proportion of oil to petrol is given on page 22, and the grades of oil recommended should be used, as lighter grades may prove unsuitable.

For correct running of the engine and also for adequate lubrication, it is essential that the oil should be completely dissolved in the petrol, and it is, therefore, preferable to use self mixing oils specially prepared for two-stroke engines as detailed in the list of recommended lubricants (page 22). Alternatively, ready-mixed oil and petrol can be obtained from dispensers kept by many garages. As the only lubrication for the engine is by means of fuel drawn in through the carburetter, the machine must not be coasted downhill for long periods with the throttle shut as the engine may suffer seizure through lack of lubrication.

The engine mainshaft bearings are automatically lubricated, those on the driving side from the chaincase, and those on the opposite side from the gearbox. Special seals prevent transference of this oil to the crankcase.

Contact Breaker Gap

In order to obtain correct timing and proper functioning of the contact breaker, the points must be set to the correct gap when in the fully opened position, and this should be checked periodically as recommended above.

The contact breaker becomes accessible following removal of the screws "G" which retain cover "F" (Fig. 6). Turn the engine until the points are fully opened and insert a feeler gauge between them. The correct gap in this position should be .012 in. (.3 mm.) and if it is found to be incorrect, slacken screw "E" (Fig. 2) and turn the eccentric pin "H" until the correct gap has been restored, finally tightening screw "E".

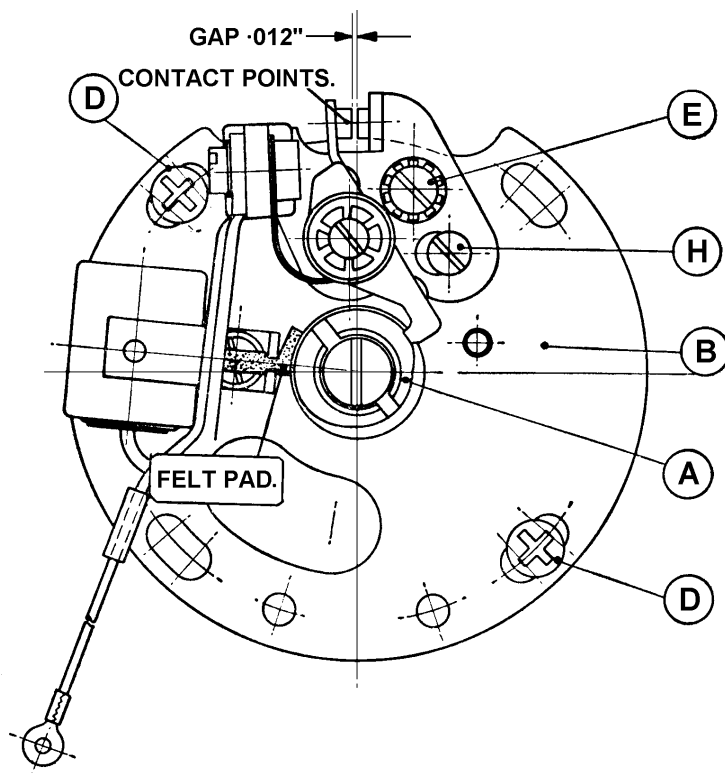

Fig. 2. The Contact Breaker

Contact Breaker Cam Lubrication.

Apply a very small amount of thin grease (preferably of the high melting point type) to the felt pad which lubricates the cam. Do not use an excessive quantity because it is most important that the contact points are kept free from lubricant, otherwise mis-firing and difficult starting may occur.

Cleaning

If the contact points are burnt or blackened, clean with a fine carborundum stone or very fine emery cloth, afterwards wiping away any trace of dirt or metal dust with a clean petrol-moistened cloth.

Ignition Timing

The ignition timing is accurately set within very close limits and there is neither provision, nor necessity, for manual adjustment of the setting. It cannot be too strongly emphasised that the ignition timing is correctly set for satisfactory engine performance and that any attempt to "improve" on the manufacturer's setting should be avoided, since it has been determined after careful development.

The contact breaker cam "A", Fig. 2, is mounted on a tapered extension of the engine main shaft and its position with reference to the piston is therefore constant.

Any variation in timing can be obtained only by moving the contact breaker plate "8" Fig. 2, which can be rotated through a very small angle after releasing the screws "D". Do not forget to re-tighten them securely after the adjustment has been made. It is emphasised that this is a "works" adjustment rather than one which the private owner is ever likely to carry out. To check the actual timing ignition, it will first be necessary to remove the primary chain cover and then adapt a degree plate to the engine main shaft, accompanied by a suitable pointer connected to a convenient stud, as illustrated in Fig. 3. Next, determine the top dead centre position of the piston. Rotation of the engine through several degrees near this position produces a very small movement of the piston which is difficult to detect. If the cylinder head is removed a straight-edge can be laid across the top of the barrel to act as a stop for the piston.

Bring the piston gently up to the straight edge by rotating the engine as far as it will go, first in one direction and then in the opposite direction. If degree plate readings are taken in each position, the point mid-way between them is easy to calculate and this will be an accurate top dead centre. Adjust the timing disc until the zero mark corresponds with the pointer.

From this position rotate the engine BACKWARDS by 18-degrees and check that with the piston in its new position, the contact breaker points are just separating (not more than .002 in. open). If they are open by more than this amount the timing is advanced excessively and vice versa.

It is essential to ensure a correct contact points gap before setting the ignition timing.

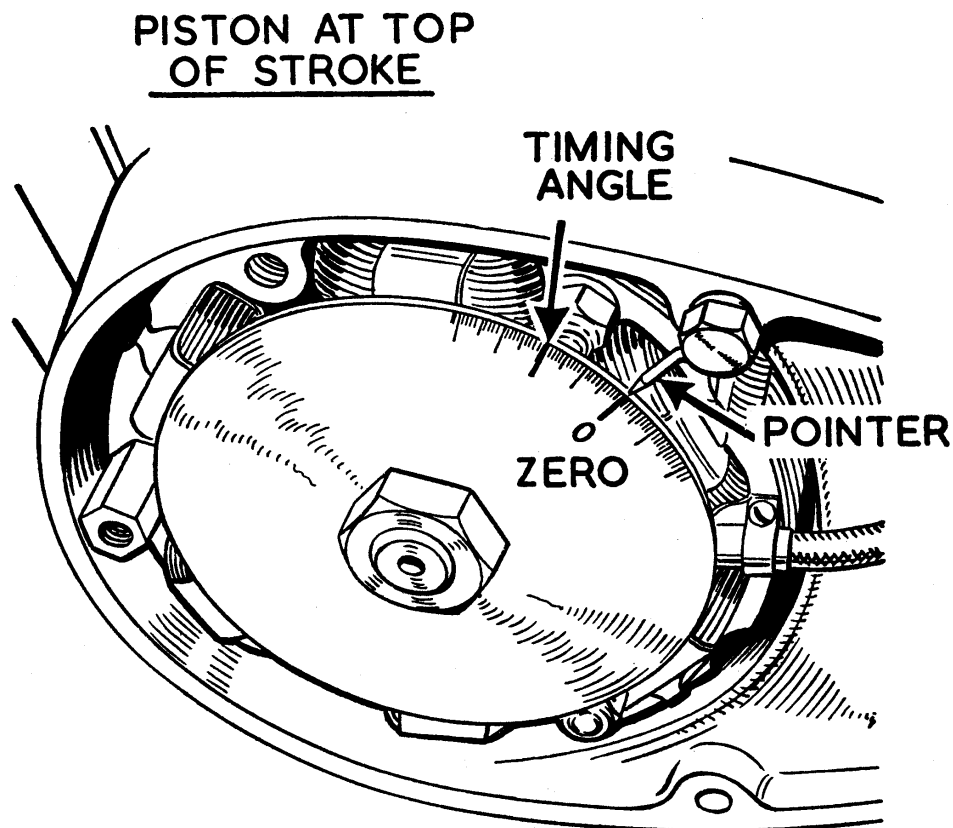

Fig. 3. Timing the engine with a degree plate

DECARBONISATION

Decarbonising is extremely simple and should be carried out at regular intervals of about three thousand miles (5,000 km.) if consistent results are to be expected. The symptoms indicating an excessive deposit of carbon are undue roughness of the engine and a tendency to pink under load, erratic running with excessive four and eight stroking, and an appreciable falling off in power. This latter item is particularly noticeable when the exhaust port becomes fouled with carbon as it causes an obstruction to the free escape of the exhaust gas, and interferes with the correct scavenging of the cylinder which is so necessary for the efficient transfer of combustible mixture from the crankcase.

Silencer

The silencer is fitted with a detachable end cap held in position by a single nut. When this is unscrewed the cap can be removed and the internal baffles which are mounted on a central tube, can be withdrawn for cleaning. This should be carried out at the same time as decarbonisation of the engine. When reassembling, make sure that the copper sealing ring is in position before replacing the end cap, and that the plain washer and the spring washer are replaced on the stud before tightening the nut.

Removal of Cylinder

First turn off the petrol and detach the petrol pipe at the carburetter. The pipe is affixed to the petrol tap union and should not be disturbed. Next, disconnect the air cleaner hose and remove the carburetter from the cylinder flange still attached to its cables and tie back out of the way. The exhaust pipe must also be disconnected by releasing the union nut at the front of the cylinder barrel using a "C" spanner for this operation. If this nut should prove unduly obstinate, a few drops of penetrating oil should be applied to the threaded portion immediately above the nut and a little time should be allowed for this to act before attempting to unscrew the nut. Remove the whole exhaust system. Disconnect the high tension lead from the sparking plug and unscrew the latter.

The cylinder head and barrel are attached to the crankcase by means of four long studs, and when the four nuts on the top of the cylinder head are removed, the head and then the barrel can easily be lifted clear. Removal of the cylinder barrel is greatly facilitated if the two petrol tank front locking bolts are unscrewed so that the tank can be raised slightly and it will also be found beneficial to slacken the two crankcase joint screws immediately below the bottom fin on the barrel. Take care when removing the barrel to support the piston as it emerges from the end of the bore to protect it from damage as it comes clear.

Removal of Cylinder (*Bushman*)

Due to the high ground clearance provided on these models, it is necessary to remove the petrol tank prior to removal of the cylinder. The tank is bolted to the frame at front and rear connections and the tap and pipe can be left in position on the tank.

Piston

Place the cylinder head and barrel on one side on a bench and examine the piston. It should not be necessary to remove this from the connecting rod, but if it should be desired to do this for any reason, first remove the circlip from one end of the gudgeon pin using a pair of pointed nose pliers or some suitable instrument to lever the circlip out. Then, with the aid of a suitable extractor, withdraw the gudgeon pin. If it is too tight to move, it can be released by warming the piston by means of a rag soaked in hot water and wrung out. Application of this rag will cause the aluminium alloy of the piston to expand more than the steel gudgeon pin, thus releasing the latter which can then be freely removed. Be careful not to damage the needle rollers comprising the gudgeon pin bearing in the connecting rod.

Scrape off any carbon which has accumulated on the crown of the piston, taking care not to damage the relatively soft surface of the metal itself, and after removing all the carbon, wipe clean with an oily rag.

Piston Rings

Now examine the piston rings noting that these are located in their grooves by means of pegs which engage in the piston ring gaps. If in good condition the rings will be found to present a uniformly smooth metallic surface over their entire peripheries, and if they are in this condition and obviously have a certain amount of “springiness” as evidenced by the fact that their free gap is considerably greater than the closed gap when in the bore, they should not be disturbed. If, on the other hand, the rings show signs of heat as evidenced by brown or more highly discoloured patches, they should be replaced by new rings, and in this case particular attention should be paid to the fit of the ends of the rings on their locating pegs in the piston ring grooves, and they should also be checked in the bore to ensure that they have an adequate gap. First place the ring in the cylinder bore in a position where it is clear of the ports making certain that it is parallel with the bore by inserting the piston with its skirt against the ring. Examine the gap which should be not less than specified (see Technical Data, page 5). Having satisfied yourself on this point, place the ring in its groove on the piston and make certain that it is free without perceptible up and down play. If it is not free and the groove itself is clean, rub the ring down on a piece of fine emery cloth laid on a flat surface, using a rotary motion of the arm to ensure uniform pressure on the ring. As soon as ring is found to be free in its groove, wipe it absolutely clean and fit it into position.

Check also that there is sufficient clearance between the inner portion of the gap and the locating peg in the groove. Do this by closing the ring in its groove by finger pressure until there is no gap, thus showing that there is clearance at the peg underneath. If the gap will not close, indicating that the steps are binding on the peg, ease the steps gently with a smooth file. If the piston has been removed from the connecting rod refit it, first putting a smear of oil on the gudgeon pin, not forgetting a new circlip to replace the one which was removed.

The piston must be replaced in its original position—i.e., with piston ring gaps towards the front.

Then put a piece of clean rag over the piston and crankcase mouth and turn your attention to the cylinder barrel and head.

Cylinder Head and Barrel

Remove all carbon deposit from the cylinder head, bearing in mind again that the aluminium is soft and easily damaged if the decarbonising tool is carelessly applied, and carefully wipe clean to ensure the removal of all loose particles. Most of the carbon deposit likely to have accumulated in the cylinder will be in the exhaust port, and cleanliness at this point is most important as explained earlier. Scrape this out carefully, taking care not to let the tool slip into the bore and damage the surface of the latter. Examine the transfer and inlet ports for the presence of carbon, although this is unlikely to be heavy, and finally wipe the ports and the cylinder bore absolutely clean.

Big end Bearing

While the cylinder is off, it is as well to test the big-end bearing for wear. This is done by taking hold of the connecting rod stem and pulling it upwards until the crank is at the top of its stroke. Then, holding it in this position, try gently but firmly to pull and push the connecting rod in the direction of its travel in order to feel whether there is any play. If the big-end is in a sound condition there should be no play in this direction although it may be possible to rock the rod sideways, i.e. at right angles to the axis of the machine. If vertical play is perceptible in the big-end and you do not feel qualified to decide whether the amount in evidence is permissible or not, you should seek expert advice. This point is not likely to give trouble, however, provided that the machine has been carefully used and adequately lubricated, for the big-end bearing is of ample dimensions for the work it has to do. But if for any reason the big-end bearing has deteriorated as the result of neglect or abuse, it should be replaced and unless you have the necessary experience and facilities for this class of work it is preferable to have it done by an expert repairer.

Re-assembly

Before attempting to replace the cylinder barrel over the piston, smear the former generously with engine oil and then place it over the piston, carefully manipulating the rings into the end of the bore and seeing that they enter freely without the application of force. As soon as the cylinder barrel is in position, replace the cylinder head and put the washers and nuts on the four holding down bolts. Tighten the nuts in diagonal order so as to avoid distortion and, if a torque spanner is being used, it should be set to 10 lb. ft.

Examine the sparking plug and replace if sound. Check the rubber sealing ring on the carburetter flange, replacing if damaged. Finally reconnect the exhaust pipe, carburetter, and petrol pipe.

Sparking Plug

The sparking plug is of great importance to satisfactory engine performance, and it is necessary that it should be the correct type and in good condition. Champion type N4 is recommended.

The condition of a sparking plus can be helpful in determining the condition and tune of an engine, and it is recommended that the plug be removed from time to time for examination.

A plug running at the correct temperature in a healthy engine will be indicated by blackish or greyish-tan deposits on the end of the plug body and earth electrode. The firing end of the insulator will vary from a very light tan to a darkish brown.

(Above)—*Fouled
with burnt oil or soot*

(Below)—*Correct*

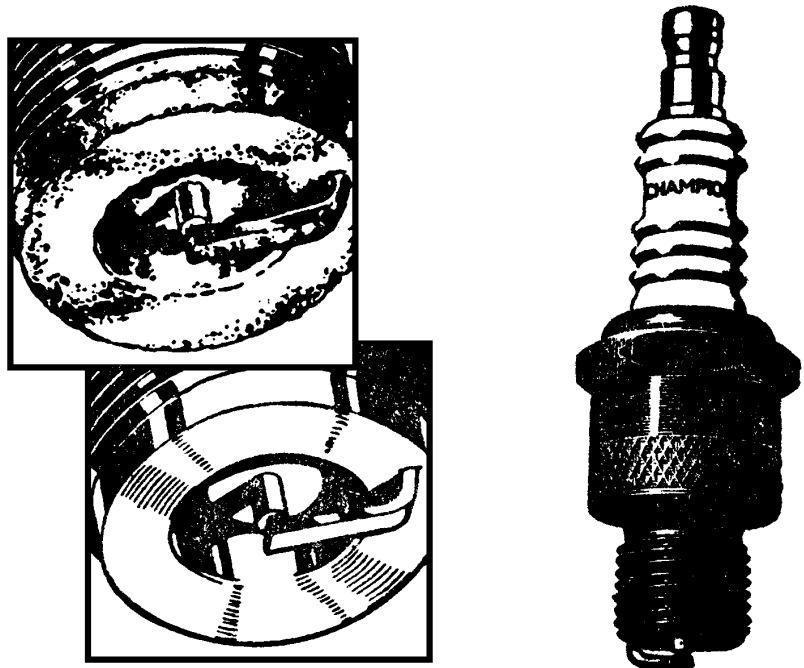

Fig. 4. The sparking plug

A sooty deposit on the firing end of the plus is generally an indication of an over-rich mixture, whereas a light grey deposit on the end of the plus and a white-ish appearance on the firing end of the insulator may indicate a lean mixture. If the carburation appears correct, but the plug insulator at the firing end is black with carbon or oily deposit, this is generally an indication that the grade of plug is too cold.

The plug should be cleaned on an abrasive blast machine and afterwards the sparking surfaces of the electrodes on standard type plugs should be dressed with a fine file in order to restore clean, flat, parallel faces. It is most important that the gap should be re-set to specification, .025 ins. Gap adjustment should be made by bending the side wire. The threads of the plug, and the gasket seat, should be wiped clean before refitting the plug to the engine. The upper portion of the insulator should also be wiped clean after fitting, and prior to connecting the H.T. cable. It is good practice to wipe periodically the top of the insulator with a clean cloth in order to remove any accumulation of grime or dust etc., as such deposits can be conductive, and result in poor plug performance.

The special non-detachable steel gaskets fitted to Champion standard sparking plugs are designed to last the life of the plug.

When refitting the plug, screw in as far as possible by hand, and then use a box spanner for final tightening, to avoid possibility of damage to the insulator. An adjustable spanner should not be used.

THE AMAL CARBURETTER

The carburetter is of simple and robust construction and the only attention that may be required is adjustment of the pilot jet and throttle stop.

An exploded view of the carburetter is shown in Fig. 5. Opening the twist grip throttle control raises the throttle slide thus controlling the supply of air to the engine. The tapered needle controlling the supply of fuel is attached to the throttle slide so that a balanced mixture is always provided. The needle has a number of notches at its upper end and it is secured in the throttle slide by the spring and by the circlip which locates in one of the notches. The throttle valve size and the needle position are carefully set before despatch from the factory and no alteration to these settings is necessary or desirable.

Mixture control at low speeds is by the pilot jet which has an adjustable air supply. An adjustable throttle stop is also provided to regulate the slow running speed. Both throttle stop and pilot air screws are fitted with "0" rings to retain the adjustment and if the screws are taken out, the rings must be carefully preserved.

To achieve good petrol economy accurate adjustment of the pilot jet and throttle stop is important. These are adjusted before the machine leaves the Works, but the best setting may vary slightly to suit rider's requirements or particular localities. The adjustment should be made with the engine warm.

Screwing in the pilot air screw restricts the air supply thus giving a richer mixture, and unscrewing it weakens the mixture. The best way to adjust is to screw in the pilot air screw until the mixture is obviously too rich and the engine starts to run irregularly, and then unscrew the adjuster until the engine runs evenly. If it is unscrewed too far the engine may cut-out or may spit back through the carburetter when the throttle is opened. When the proper adjustment has been determined, the engine may be running too fast and in this case the throttle stop should be unscrewed. If considerable alteration to the throttle stop has been made, the pilot air screw should be re-adjusted.

In the case of blockage, the jets are exposed after removal of the float bowl, the main jet requiring a suitable spanner for removal and a small screwdriver for the pilot jet. Removal of the float bowl will be simplified if the carburetter is first detached from the cylinder barrel, when the screws securing the bowl become readily accessible.

No advantage will be gained by altering the jet sizes from those recommended.

Carburetter Air Control

The air slide in the carburetter is cable-controlled from a lever on the right handlebar (Fig. 1). To close the air slide, the lever must be pushed away from the rider (anticlockwise rotation) thus enriching the mixture. The air slide is opened by turning the lever as far as possible in a clockwise direction and it should be kept in this position at all times except when starting from cold.

Special Note.—New riders especially are advised to study the action of the air control and to treat this device with respect. It should only be used *momentarily* when starting from cold and even then only when necessary. Immediately the engine fires it should be opened. This point is of special importance in the event of difficult starting, possibly due to some other circumstance such as a defective sparking plug, because repeated operation of the starter pedal with the air control closed results in the accumulation of liquid petrol in the crankcase and when this occurs, starting is quite impossible until it is drained away by the removal of the crankcase drain plug, which is the smaller of the two plugs under the crankcase.

Air Cleaner (*Supreme and Sports models*)

This is concealed behind the right side panel which must be removed first. The air cleaner element is retained by a flexible strap and, following its removal, the element can be withdrawn. It should be cleaned at intervals of about 2,000 miles. Wash the filter element thoroughly in petrol, allow to dry, and re-assemble. Failure to clean the filter regularly may cause it to become partially choked with a consequent deterioration in petrol consumption and performance.

Air Cleaner (*Bushman model*)

The air cleaner is mounted below the seat and must be taken out for cleaning. Remove the seat and then the right side panel, when the filter fixing bolts and hose dips become accessible, and the complete filter assembly can be withdrawn.

Removal of the clip screws allows the unit to be dismantled and the filtering element to be extracted.

The element is made of a specially treated paper and should receive attention at a maximum mileage of 1,000—more frequently in exceptionally dusty climates. It is preferable for the element to be replaced regularly but where this is not possible, it should be well brushed to remove all traces of dust and the interior of the container treated similarly.

Failure to clean the filter regularly may cause it to become partially choked, with a consequent deterioration in petrol consumption and performance.

- 9. NEEDLE
- 10. AIR SLIDE
- 11. THROTTLE SLIDE
- 14. PILOT JET
- 15. NEEDLE JET
- 16. NEEDLE JET HOLDER
- 17. MAIN JET
- 18. FLOAT NEEDLE
- 19. FLOAT
- 26. THROTTLE STOP SCREW
- 27. PILOT AIR SCREW

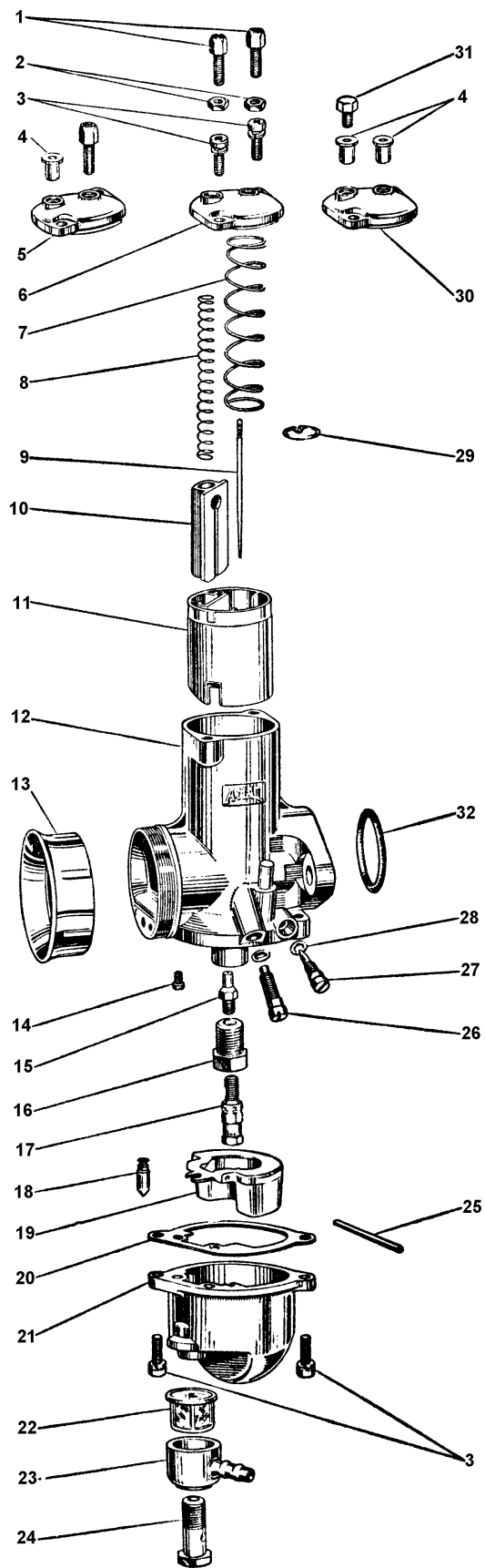

Fig. 5. The Amal concentric carburettor

LIST OF RECOMMENDED LUBRICANTS

All the engine oils listed below are self-mixing and must be used in the proportion of 1 part oil to 24 parts petrol (i.e. 4% mixture), given by the following:—
 $3\frac{1}{2}$ filler cap measures of oil to 1 gallon of petrol.

If non self-mixing two-stroke oil is used, (or alternatively, an S.A.E. 40 grade of oil), the proportion is 1 part oil to 32 parts petrol (i.e. 3% mixture) given by $2\frac{1}{2}$ measures to 1 gallon petrol.

Note: For running-in purposes one extra measure may be added.

Brand	Oil		Grease Points	Front Forks
	Engine	Gearbox		
Castrol	Castrol Two-Stroke Oil	Castrol XXL	Castrolase L.M.	Castrolite
Shell	2T Two-Stroke Oil	Shell X-100 40	Shell Retinax A	Shell X100-20
Esso	Esso Two-Stroke (2T) Motor Oil	Esso Extra Motor Oil 40/50	Esso Multi Purpose Grease H	Esso 20W/30
Mobil	MobilMix TT	Mobiloil BB	Mobilgrease MP	Mobiloil Arctic
BP	Energol Two-Stroke Oil	Energol SAE 40	Energrease L2	Energol SAE 20
Regent	Motor Oil 2T	Havoline SAE 40	Marfak Multi purpose 2	Havoline SAE 20W

Important Note: Self-mixing oils are specially prepared for use in two-stroke engines and their use is strongly preferred.

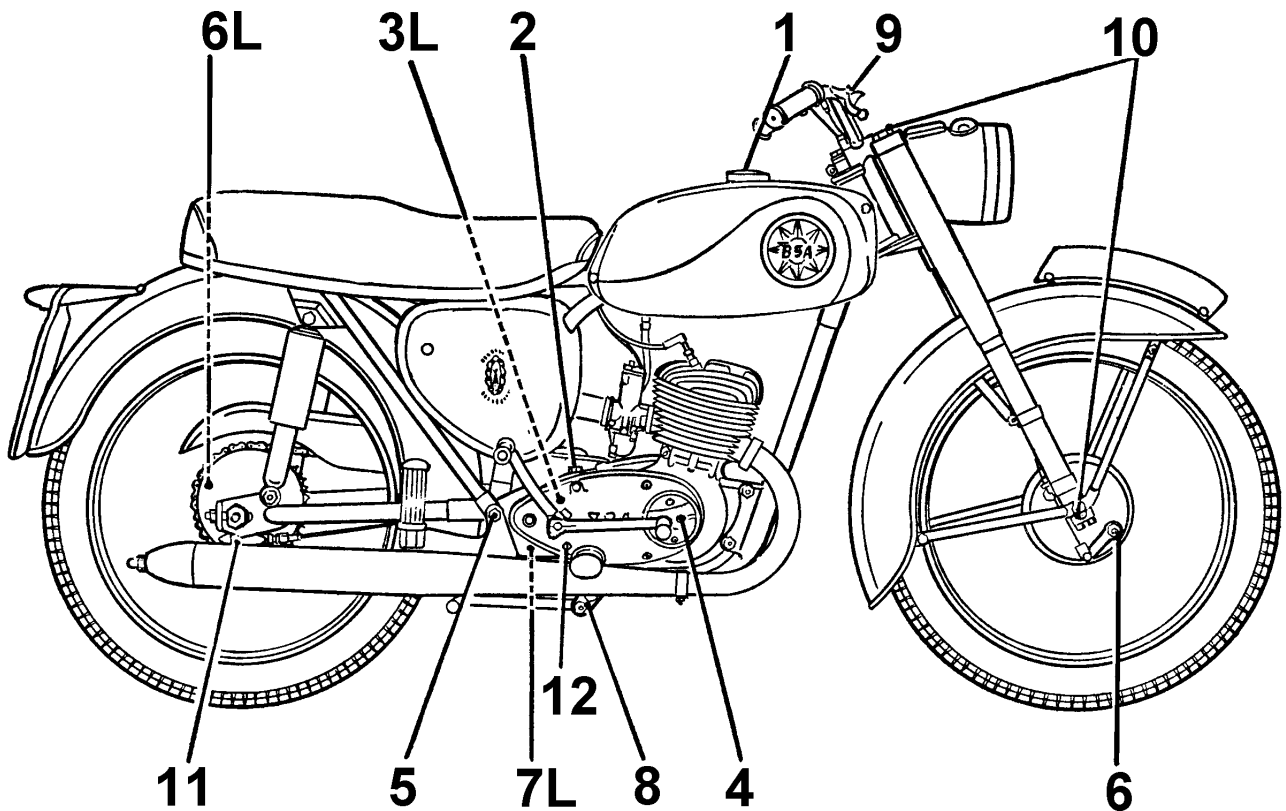

KEY LUBRICATION POINTS

(L indicates left hand side, remained right hand side or both sides).

The illustration shows the Bantam Supreme.

Lubrication details for the other models are the same.

OIL. (See Chart page 22)

No.	Item	Page
1	Petrol Mixture	12 & 22
2, 12	Gearbox and Primary Drive	12 & 26
10	Front Forks	12 & 28

GREASE

No.	Part	Page
3	Clutch Control	21 & 25
4	Contact Breaker Cam Pad	12 & 13
5	Swinging Fork Pivot	12 & 30
6	Brake Cams	12
11	Speedometer drive	12 & 27

A FEW DROPS OF ENGINE OIL

No.	Part	Page
7	Brake Pedal	12
8	Central Stand	12
9	Handlebar Levers	12
—	Control Joints and exposed cables <i>(not illustrated)</i>	12

TRANSMISSION

Front Chain

The front chain runs on short fixed centres and adjustment is neither required nor provided.

The chain will run for many thousands of miles before examination is required. This operation involves the removal of the primary chain cover (Fig. 6), after the starter and gear change pedals, both of which are mounted on splines and locked by pinch bolts "B" and "C" respectively, have been removed, together with the five securing screws "D". The normal up and down play on the front chain is up to $\frac{3}{8}$ in. (1 cm.) and the maximum permissible, indicating that the chain is unduly worn and requires replacement, is about $\frac{3}{4}$ in. (2 cm.).

Primary Chain Lubrication

This has a common oil supply with the gearbox and therefore does not require separate attention, beyond the instructions for the gearbox.

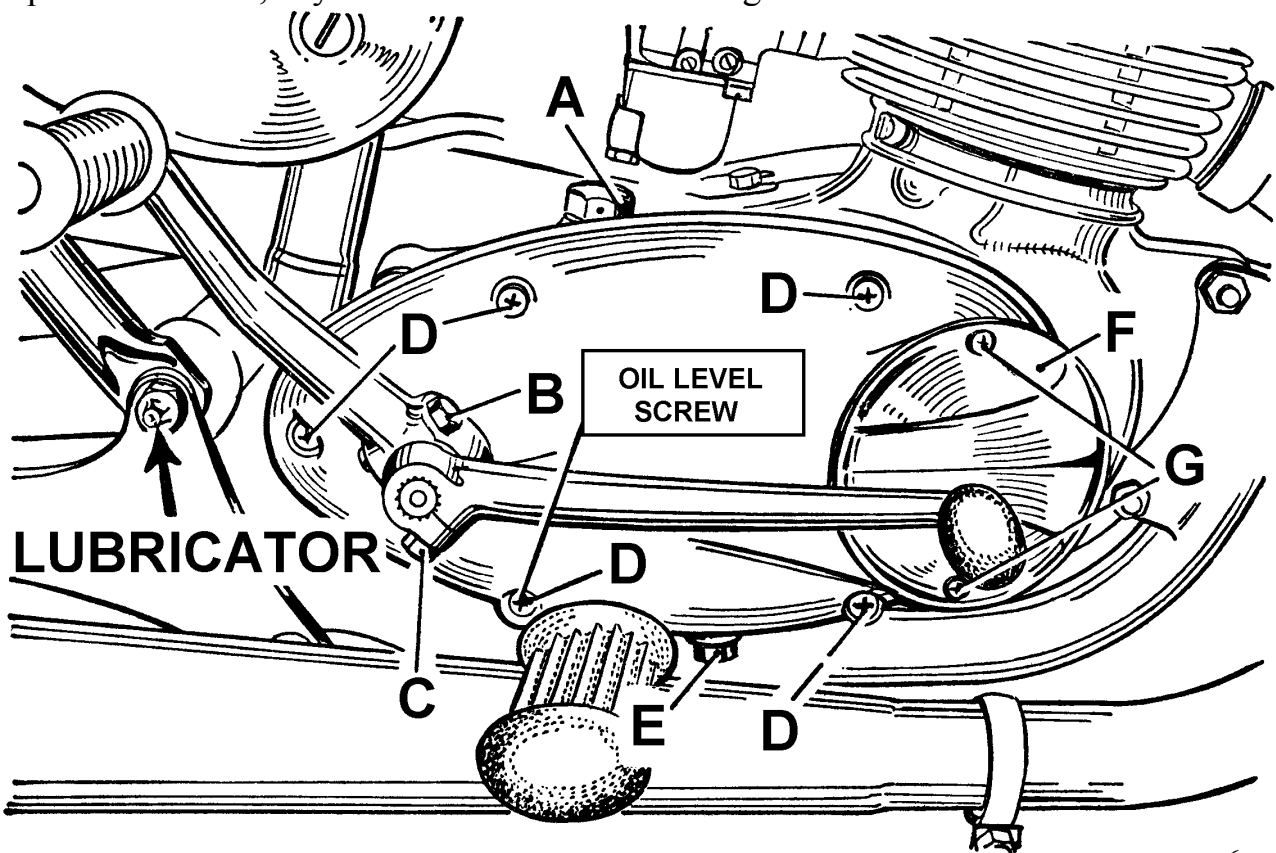

Fig. 6. Primary drive

The Bantam Supreme is shown, but details apply to all models.

Care of the Rear Chain

It is a good plan periodically to remove the rear chain, clean it thoroughly in petrol or paraffin, and then gently warm in a mixture of grease and graphite. When cool wipe off excess grease, clean sprockets and replace chain. Remember when replacing the chain, which is fitted with a detachable connecting link, that the spring fastener must always be put on with the closed end pointing in the direction of travel of the chain (i.e. on the lower run of the chain, the closed end should be rearward).

Rear Chain Adjustment

Adjustment of the rear chain involves moving the rear wheel and is described on page 27.

Clutch Control

The clutch adjustment will be found at the left-hand end of the gearbox mainshaft (see Fig. 7) and it consists of an adjusting pin *C* screwed into the clutch withdrawal sleeve and a locknut *B* to secure it in position. These items are accessible through an aperture in the outer cover, after removal of the rubber cap, or by removal of the complete outer cover. The adjusting pin presses against the clutch withdrawal rod with a steel ball interposed and the withdrawal mechanism must at all times be so adjusted that there is a slight amount of play between the pin, the steel ball, and the operating rod, in order to ensure that the clutch springs may exert their full pressure on the driving and driven plates. If there is not sufficient play there will be a tendency for the clutch to slip continually owing to reduced spring pressure, and this in turn will cause over-heating and serious damage to the clutch itself.

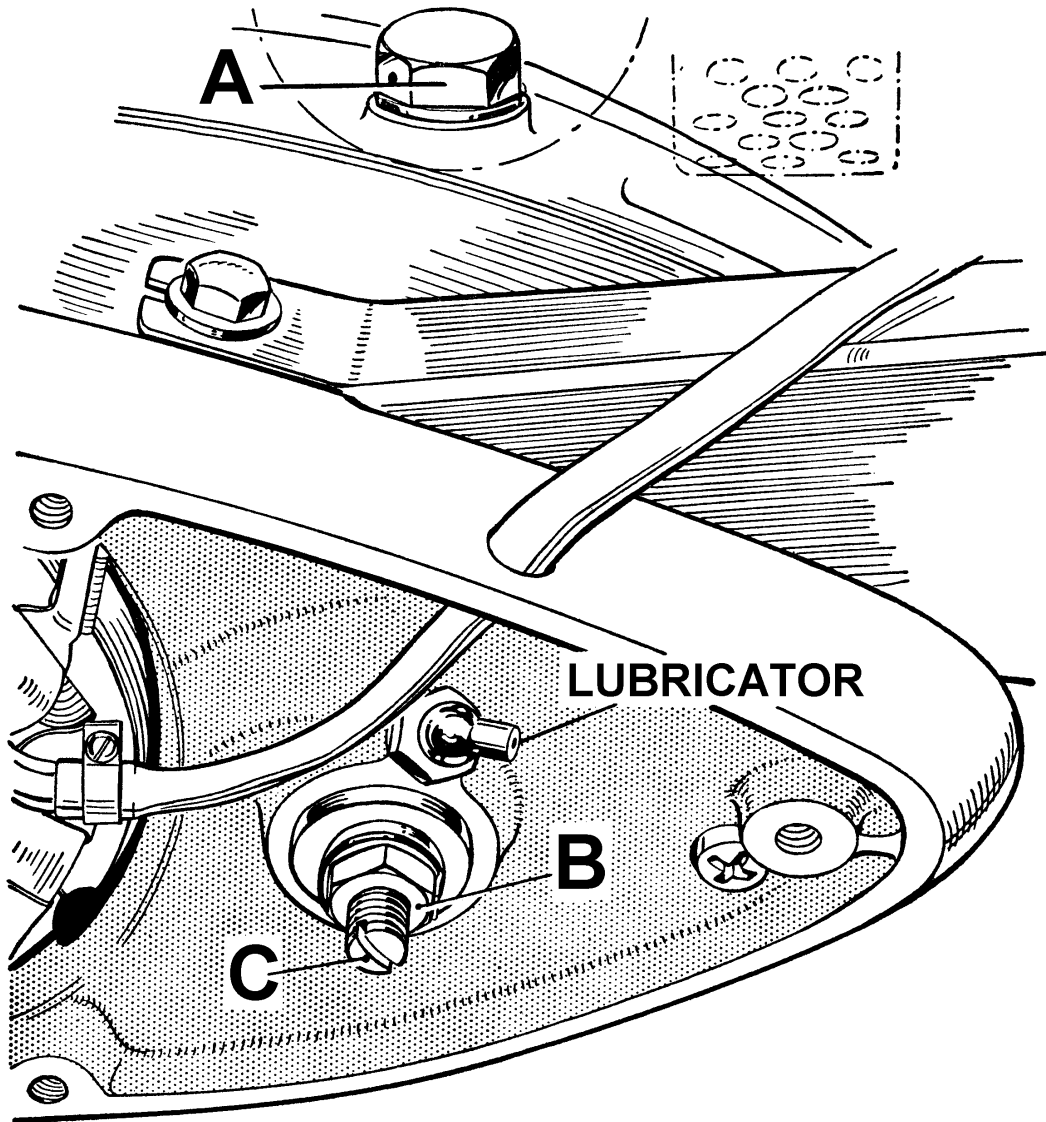

Fig. 7. Clutch control adjustment, with outer cover removed.

If the play becomes excessive, difficulty will be experienced in changing gear, as the clutch may not fully disengage, in which case the control should be adjusted as explained below.

To adjust, release the locknut and holding it with a spanner unscrew the adjusting pin with a screwdriver one or two turns. Still holding the locknut with a spanner, screw the adjusting pin gently in until it is felt to meet some resistance. Then unscrew it half-a-turn and holding it in this position retighten the locknut. If the adjustment is correctly made in this manner, it will be found that there is a small amount of free play at the clutch lever on the left handlebar before this is felt to take up the spring pressure during the action of declutching.

The clutch operating mechanism should be greased at regular intervals to maintain it in good condition (see Page 12).

Clutch Dismantling

Before dismantling the clutch, the primary chain case cover must be removed as described under Front Chain on page 24. The clutch springs must be compressed by pressing the outer plate inwards until the circlip retaining the spring pressure plate can be removed. Care must be taken to see that the springs are properly compressed as damage may result if they are released suddenly and the job is best accomplished with the aid of special clutch spring compressing tool 61-3191. When the spring pressure plate is removed the four plates carrying friction pads can be withdrawn, together with their mating plain plates. If the pads are burnt or otherwise damaged, the plates should be replaced.

Gearbox

The gearbox, although built in unit construction with the engine, is self contained as regards lubrication. An engine oil of S.A.E. 40 grade (page 22) is used for lubricating the gears and primary drive, but self-mixing engine oils must not be used.

To change the oil in the gearbox, remove drain plug *E* (Fig. 6) at the bottom of the gearbox and drain out the old oil. Wash out the gearbox with flushing oil and refill with new oil through filler hole *A* (Fig. 7) to the appropriate level.

The correct level is given by the screw *D* (Fig. 6) situated on the primary drive cover behind the footrest. The screw is painted red for ease of identification and must be removed when refilling the gearbox. Replenish until oil flows from the level screw hole and when any surplus oil has drained off, replace the screw firmly, followed by the filler plug.

WHEELS

Hubs

These are fitted with ball journal bearings, and no adjustment is either provided or required. The bearings are packed with grease during assembly and this should last until the machine needs a complete overhaul.

Speedometer gearbox

The unit requires no attention apart from lubrication at intervals (see page 12) Grease with two applications from a **hand grease gun** only.

Front Wheel Removal (*Bantam Supreme*)

Disconnect the brake cable at the lever on the brake cover plate and then remove the nut securing the cover plate to the fork leg. Remove the caps at the bottom of the fork legs, supporting the wheel as this is being done and withdraw the wheel. When replacing make sure the spindle ends are level with the end faces of the caps and that the cover plate nut is securely tightened.

Bantam Sports and Bushman

Wheel removal is similar to that for the Supreme model except that the brake cover plate is anchored by a tongue on the fork leg. Make sure that the tongue and the slotted brake plate are properly engaged when the wheel is replaced.

Rear Wheel Removal

Disconnect the speedometer cable from the drive unit and unscrew the adjuster from the brake rod. The rear chain should be disconnected at its spring link and unwound from the rear wheel sprocket. It is advisable to leave the chain in position on the gearbox sprocket. It will also be necessary to uncouple the brake plate arm from the swinging fork at C (Fig. 8). Finally, slacken the spindle nuts sufficiently to allow the wheel to be withdrawn. During re-assembly make sure that the brake plate bolt is securely tightened. Check also that the chain adjusters are firmly against the fork ends.

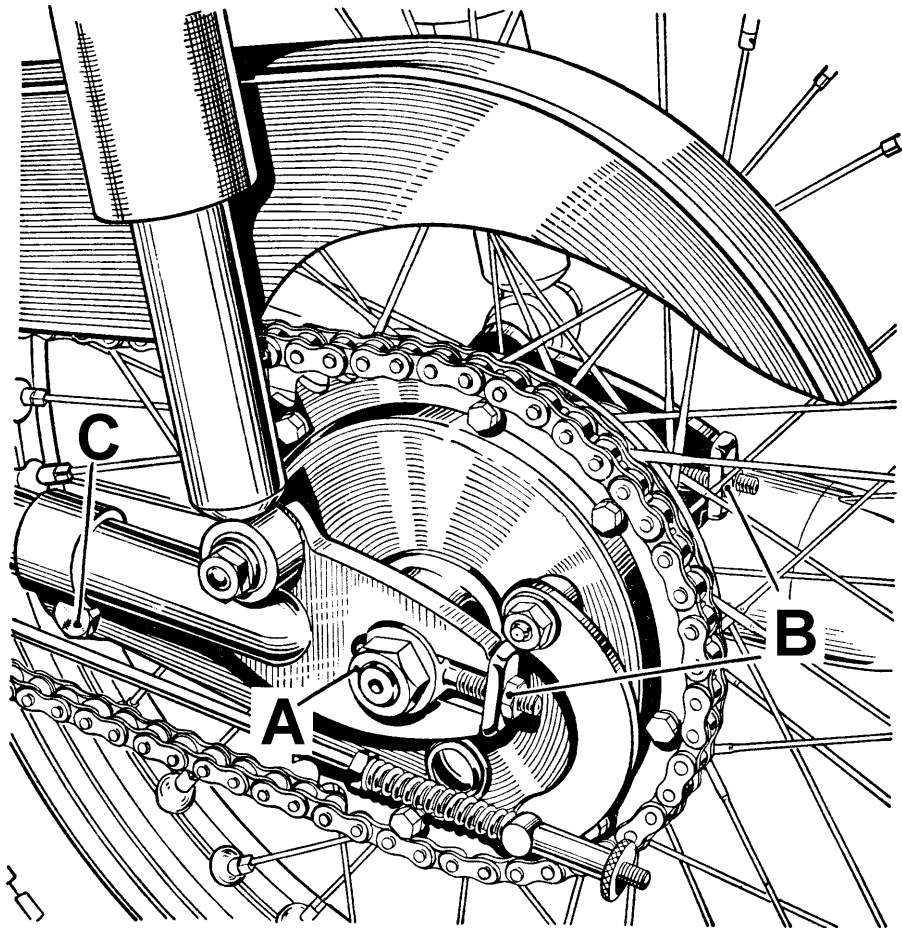

Fig. 8. Rear Chain Adjustment

The illustration is for the Supreme and Bushman models. The Sports model is similar except for full width hub, and the method of adjustment is the same for all models.

Rear Chain

The rear chain is adjusted by means of draw bolts at the fork ends at the back of the wheel spindle. First slacken off the brake adjuster, as the brake rod may prevent free movement of the wheel. Next, loosen the nut on the inside of the brake plate arm at *C*, to allow the slotted arm to accommodate itself to a new position when the wheel is moved. It is not necessary to disturb the speedometer drive unit. Slacken off the spindle nuts *A* (Fig. 8) and tighten the adjusting nuts *B* until the chain tension is correct.

The chain should be adjusted with the machine on its stand, i.e., with the rear wheel in its lowest position in the rear suspension. The adjustment is correct when the total up and down movement in the centre of the chain run at its tightest point is $\frac{3}{4}$ in.

Make sure that the adjusters are firmly against the fork ends when checking, and also that the adjustment is equal on both sides of the wheel so that the latter is in correct alignment in the frame. This can be done either by glancing along the line of both wheels when the front wheel is set straight, or by means of a long straight-edge or the edge of a plank placed along the sides of the wheels. The straight-edge should touch the wall of each tyre in two places.

After adjusting, do not forget to retighten nuts *A* and *C*.

Brakes

The brakes should be adjusted whenever the handlever or foot pedal movement has become excessive. The shoes should be just clear of the drum when the brake is off, but close enough for immediate contact when the brake is applied. The brakes must not be adjusted so closely however, that they are continually in contact with the drum, otherwise excessive heat may be generated resulting in deterioration of braking efficiency.

In the case of the rear brake a sleeve nut on the brake rod effects any adjustment necessary, and a few turns are all that are required to improve braking efficiency. The front brake is adjusted by means of the knurled ring nut on the cable stop at the lower end of the forks.

STEERING AND SUSPENSION

Under normal conditions the only servicing which the front forks require is occasional renewal of the oil. The need for this may be indicated by excessive movement of the forks, but it should only be necessary after considerable mileage.

Bantam Supreme

Prise out the cap on the top of the fork leg by means of the small hole provided for the purpose, and with the aid of a tubular spanner unscrew the small nut thus exposed. Then remove the large nut which carried the cap. Disconnect the mudguard stay at the lower end of the fork leg, and unscrew the stud. Allow all the oil to drain out, then apply the front brake and depress the forks a few times to drive out any oil remaining in the system. Replace the drain stud and fibre washer.

Add $\frac{1}{8}$ pint of an S.A.E. 20 oil to each leg (see lubrication list, page 22) and replace the top nuts and cap.

Bantam Sports and Bushman

The procedure for draining and re-filling the forks is as above except that the filler is a single cap nut on top of the fork leg and a drain screw is provided at the bottom of the fork sliding member, near to the wheel spindle.

$\frac{1}{6}$ pint of an S.A.E. 20 oil is required in each leg.

Steering Head Adjustment (*All models*)

It is first necessary to raise the front wheel clear of the ground—this can best be done by lifting the machine on its stand and putting some small weight on the rear of the machine causing the rear wheel to rest on the ground. Test for play by grasping the fork legs and attempting to push them backwards and forwards. If play can be detected the head bearing requires adjustment.

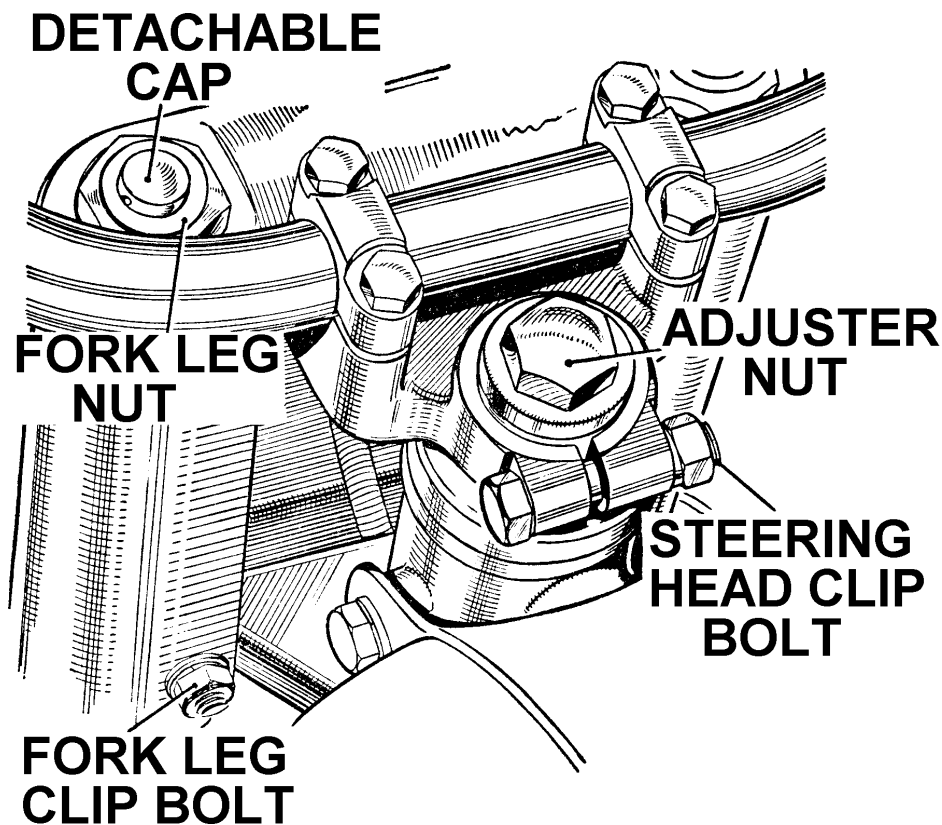

Fig. 9. Front fork and steering head (Bantam Supreme)

Slacken the clip bolt on each fork leg below the lamp so that the bottom yoke is free to take up a new position.

Release the steering head clip bolt Fig. 9, and tighten adjuster nut until any slackness has been taken up. Do not over-tighten or steering will be stiff and the ball races may be damaged. Finally, retighten the steering head clip bolt followed by those on the bottom yoke. To check, hold the handlebars lightly and move them round slowly, when the steering should be free and rotate smoothly.

Rear Suspension

The two suspension units each comprise a telescopic damper unit and a totally enclosed coil spring. The hydraulic dampers require no attention whatsoever. They are sealed during manufacture and if they suffer damage or become ineffective they must be replaced.

The complete suspension units can be removed from the frame after detaching the pivot bolts at the top and the retaining nuts at the bottom.

The swinging fork pivot is provided with grease nipples and should be thoroughly lubricated every 1,000 miles.

THE ELECTRICAL SYSTEM

(Supreme and Sports models)

The lighting and ignition systems are fed by a simple 6 pole alternator generating set which supplies current through a metal plate rectifier to the battery, this then feeding the ignition system, lights, horn, etc., through the appropriate switches.

The alternator stator carries 6 coils which are wired in three sets of two series-connected coils. With the lighting switch in the "Off" and "Low" positions, two coils only are in operation, but when the headlight is in use or the emergency ignition is selected, all six coils are in circuit. Regulation of the charging rate is achieved by linking pairs of alternator coils according to the positions of the head light and ignition switches.

The alternating current supplied by the generator is converted to direct current by means of the rectifier, which is of the full wave bridge connected type.

The main connections in the system are made by socket connectors to the lighting and ignition switches, and by individual insulated snap connectors in the wiring. These connectors are not intended as plugs and sockets for frequent manipulation and are only for use when testing or fault finding. It is extremely important that they should be making perfect connection, as should all other connection points throughout the system.

Emergency Starting

The alternator equipment includes an emergency starting system which, when the ignition switch is moved to the emergency position, connects all six coils together and, providing that the lighting switch is in the "Off" position, gives full output in order to restore the voltage of a discharged battery. Under these conditions an immediate start can be made. The maximum charging current in the emergency position is very high because there is no reduction in current due to the lighting system, and the engine should not be run with the switch in this position for more than 10-15 minutes.

Battery

At weekly intervals, take off the left side panel to expose the battery. Release its wire retaining clip, take off the lid and withdraw the battery through the aperture.

Remove the filler plugs from each of the cells and examine the level of the electrolyte. If necessary, add sufficient distilled water to bring the level of the electrolyte up to the top of the separators. Do not use tap water and do not use a naked light when examining the conditions of the cells.

The condition of the battery should occasionally be checked by taking hydrometer readings of the specific gravity of the electrolyte. If distilled water has been added a reading should not be taken until after the machine has been used.

Never leave the battery in a discharged condition as it will suffer permanent damage. When standing idle, the battery should be given a freshening charge at least once a month. Twelve hours at .8 ampere is recommended. Keep the top of the battery clean and smear the terminals with vaseline to prevent corrosion.

A positive earth wiring system is employed. Make sure that the battery is connected correctly, i.e. with the positive (+) side of the battery connected to earth.

The coloured lead must be connected to the battery NEGATIVE (−) terminal, and the translucent (earth) lead to the battery POSITIVE (+) terminal.

Generator

The generator consists of two assemblies, namely, the magnetic rotor, and the stator which carries the six low tension coils. The rotor carries six laminated magnetic pole pieces; it is self-keeping and may be separated from the stator without any loss of magnetism.

The set requires practically no maintenance, but if the stator is removed for inspection or replacement at any time, the soldered connections which are visible should be checked to ensure that none is touching another, nor touching earth.

Before replacing, ensure that the pole faces are free from metallic dust and that the main cable is clear of all moving parts.

Running without a Battery

It is not advisable to run without a battery in circuit, because if the lights should be inadvertently switched on whilst the engine is running, all bulbs will immediately fuse. Furthermore, there is serious risk of burning out the rectifier.

Rectifier

Provided that the leads are securely attached to the rectifier, and the rectifier casing is kept clean, no service or adjustment should be required. Since the rectifier is air-cooled it is important to ensure that the air-flow, created whilst the machine is in motion, is not obstructed.

Contact Breaker Unit

Cleaning, lubrication, and gap setting of the contact breaker points are fully described on page 12.

Horn

If necessary the horn may be adjusted by means of the small screw in the back of the body. A slight turn to left or right while depressing the horn button will enable the best note to be obtained.

Headlight

The front, together with the reflector and bulb assembly, is secured to the main casing by means of a slotted screw above the lamp rim.

To replace a bulb therefore, it is only necessary to loosen the screw until the rim can be removed. To replace the double filament bulb, press the bulb retainer inwards and turn slightly anti-clockwise, when it can be lifted off and the bulb withdrawn. A replacement bulb automatically provides correct relationship of the filaments.

The best way of checking the setting of the lamp is to stand the motor cycle in front of a light coloured wall at a distance of about 25 feet. If necessary, slacken the two screws on the nacelle rim or lamp side according to model, and move the lamp until, with the main driving light switched on, the beam is projected straight ahead and parallel with the ground. With the lamp in this position, the height of the beam centre on the wall should be the same as the height of the centre of the headlamp from the ground.

Rear Lamp

A single bulb is used for both stop and rear light purposes.

The transparent red plastic portion of the lamp can be removed by unscrewing the two countersunk screws.

Stop Light Switch

This is operated by the brake rod through a spring. It is desirable to see that any mud or grease is periodically cleared away from the switch, and the operating mechanism should be oiled occasionally with thin oil.

Wiring Diagram

A diagram of the electrical circuit appears on page 34. The insulation of the wires is individually coloured and these colours are indicated on the diagram.

The wiring is connected by means of snap connectors at various convenient places on the machine and it is desirable occasionally to check it over and make certain that these connectors are tight.

BULB TYPES

Headlamp (main bulb)	6 volt, 30/24 watt. pre-focus.
Headlamp (pilot bulb)	6 volt, 3 watt. M.E.S.
Rear-Stop light bulb	6 volt, 6/18 watt. S.B.C.
Speedometer bulb	6 volt, .6 watt. B.A. 7S Lug Cap.

THE ELECTRICAL SYSTEM

(Bushman model)

The lighting and ignition systems are fed by a simple 6-pole alternator generating set supplying the ignition system, which incorporates an ignition coil designed especially to operate on the energy transfer principle, and also the lights and horn which are operated through the switches mounted on the headlight body or handlebar respectively.

The alternator carries six coils, of which two feed the lights, two more feed the horn and the remaining two individually serve the external ignition coil and the stop-light.

The main connections in this system are made by socket connectors to the lighting switch and by individual insulated snap connectors in the wiring. The connectors are not intended as plugs and sockets for frequent manipulation and are only for use when testing or fault-finding. It is extremely important that they should be making perfect connection, as should all other connection points throughout the system.

Generator

The generator consists of two assemblies, namely, the magnetic rotor, and the stator which carries the six low tension coils. The rotor carries six laminated magnetic pole pieces; it is self-keeping and may be separated from the stator without loss of magnetism.

The set requires practically no maintenance, but if the stator is removed for inspection or replacement at any time, the soldered connections which are visible should be checked to ensure that none is touching another, or touching earth.

Before replacing, ensure that the pole faces are free from metallic dust and that the main cable is clear of all the moving parts.

Contact Breaker Unit

Cleaning, lubrication, and gap setting of the contact breaker points are fully described on Page 12.

Head Light

The front, together with the reflector and bulb assembly, is secured to the main casing by means of a slotted screw below the lamp rim. To replace a bulb, therefore, disengage and withdraw the front rim and light unit assembly, removing the lower edge first.

To replace the double filament bulb, press the bulb retainer inwards, and turn slightly anti-clockwise, when it can be lifted off and the bulb withdrawn. Replacement bulb automatically provides correct relationship of the filaments.

The best way of checking the setting of the lamp is to stand the motor cycle in front of a light-coloured wall at a distance of about 25 ft. If necessary, slacken the two screws on the lamp side, and move the lamp until, with the main driving light switched on, the beam is projected straight ahead and parallel with the ground. With the lamp in this position, the height of the beam centre on the wall should be the same as the height of the centre of the lamp from the ground.

Rear Lamp

A single bulb is used for both stop and rear light purposes. The transparent red plastic portion of the lamp can be removed by unscrewing the two countersunk screws.

Stop Light Switch

This is operated by the brake rod through a spring. It is desirable to see that any mud or grease is periodically cleared away from the switch, and the operating mechanism should be occasionally lubricated with thin oil. Check also that the cable sleeve at the switch connection is in good order.

Wiring Diagram

A diagram of the electrical circuit appears on page 35. The insulation of the wires is individually coloured and these colours are indicated on the diagram.

The wiring is connected by means of snap connectors at various convenient places on the machine and it is desirable occasionally to check it over and make certain that these connectors are tight.

BULB TYPES

Headlamp (main bulb)	6 volt, 24/24 watt. pre-focus.
Rear-Stop light bulb	6 volt, 6/18 watt. S.B.C.
Speedometer bulb	6 volt, .6 watt. B.A. 7S Lug Cap.

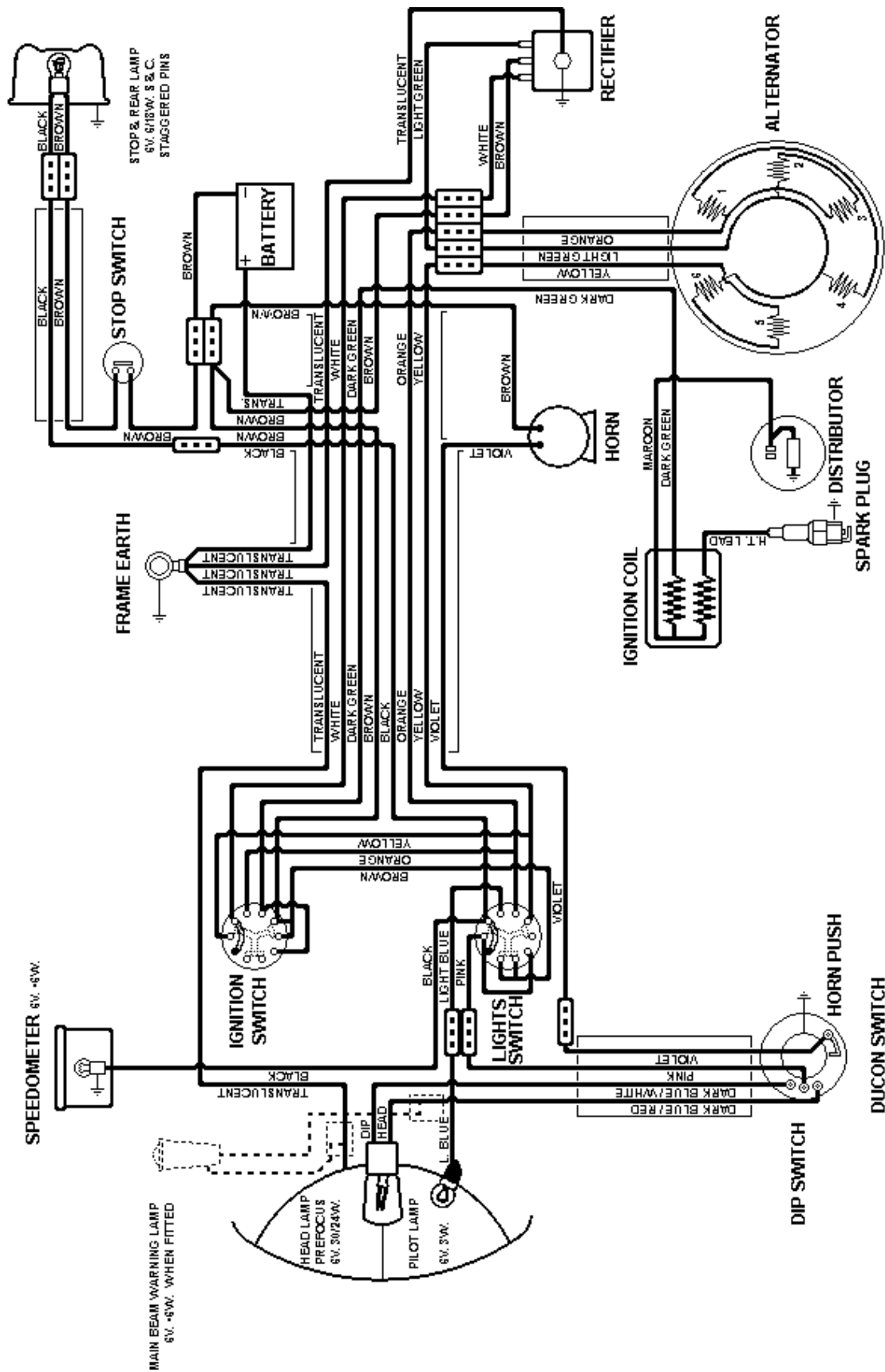

Fig. 10. Wiring Diagram (Supreme and Sports models)

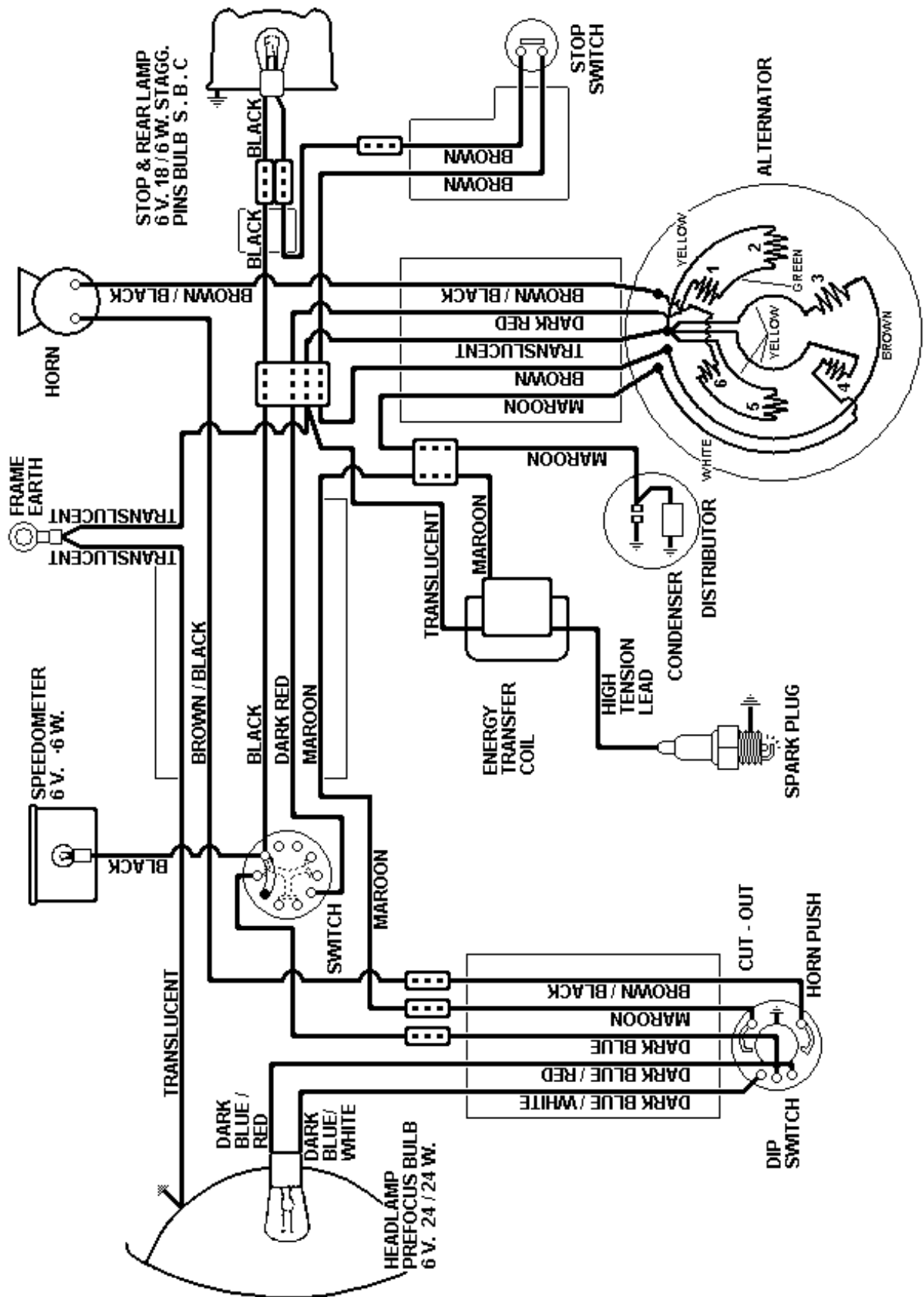

Fig. 11. Wiring Diagram (Bushman model)